

ASSP Magnetic Disk

BIPOLAR

Read/Write Amplifier

(For HDD MR and Thin Film Composite Heads, 6 Channels)

MB4138

DESCRIPTION

The MB4138 is a 6-channel read/write amplifier IC for magneto-resistive (MR) and inductive thin film composite heads used in hard disk drives.

FEATURES

- Drives six MR and thin film composite heads.
- The bias current for the MR head can be set in the range of 5 to 12 mA (DC).
- The read signal from the MR head is directly connected to the internal differential amplifier.
- High gain ($\times 150$), low noise ($0.51 \text{ nV}/\sqrt{\text{Hz}}$) read amplifier
- Read amplifier output buffer type: open collector.
- Voltage output function pin for MR heads (VHR)
- VHR pin ground fault protection function
- Read output voltage stabilization at mode switching
- Psuedo-ECL level differential input for write data
- The write current can be set in the range from 10 to 40 mA (DC).
- Internal write-unsafe detect circuit. Detects write head faults.
- TTL level control inputs
- Internal voltage monitor detects low supply voltage
- Operates on a single +5.0V power supply.

PACKAGE

48 pin, Plastic QFP

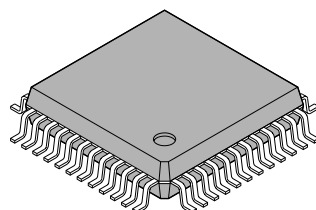

(FPT-48P-M13)

MB4138

■ PIN ASSIGNMENT

(TOP VIEW)

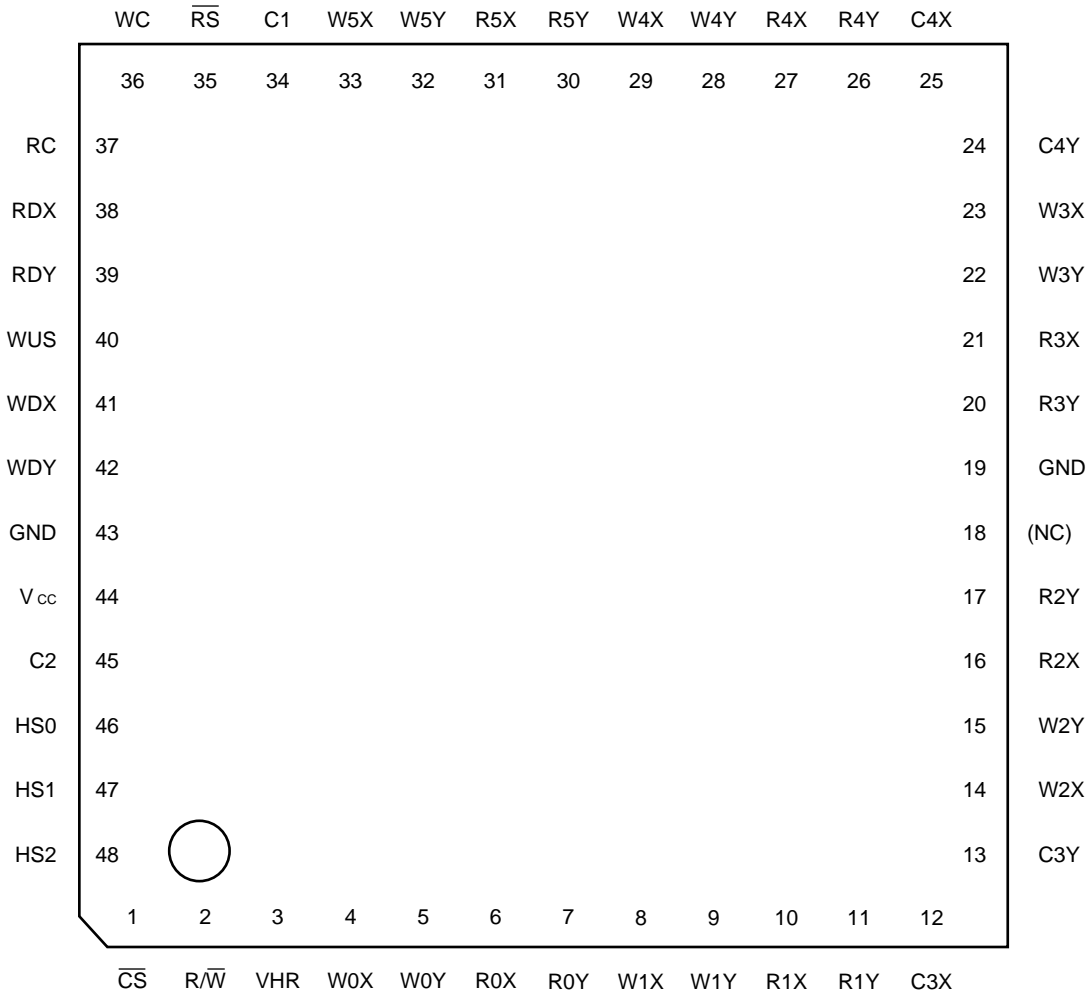

(FPT-48P-M13)

■ PIN DESCRIPTION

Pin no.	Symbol	Description
1	\overline{CS}	Chip select pin. Control signal input pin. Sets the IC to the operating or idle state. An "L" level input sets the IC to "operating".
2	R/ \overline{W}	Read/write mode selection pin
3	VHR	Output pin for the MR head voltage function. Outputs the same voltage as the bias voltage for the MR heads.
4 to 11, 14 to 17, 20 to 23, 26 to 33	W0X, W0Y R0X, R0Y W1X, W1Y R1X, R1Y to W5X, W5Y R5X, R5Y	Head connection pins for channels 0 to 5. Pins W0X, W0Y, etc. are for the thin film write heads for each channel. Pins R0X, R0Y, etc. are for the MR read heads for each channel. The MR head bias current flows from the R0X pin to the R0Y pin. The read signals are input to a differential amplifier.
12	C3X	Capacitor connection pins. A 0.033 μ F capacitor is typically connected between these pins. The capacitor cuts the DC component that occurs when a bias current flows through an MR head.
13	C3Y	
19	GND	Ground pin. Connect to ground.
24	C4X	Capacitor connection pins. Connect a 0.033 μ F capacitor between these pins. The capacitor cuts the DC component due to the bias current flowing through the MR heads.
25	C4Y	
34	C1	Capacitor connection pin. Connect a 0.1 μ F capacitor between this pin and ground. The capacitor stabilizes the current source circuit and reduces noise.
35	\overline{RS}	ON/OFF switching pin for the MR head bias current in write mode. Normally fix this pin at the "L" level (bias current ON) to reduce the duration of the transient when switching from write mode to read mode.
36	WC	Resistor connection pin for setting the write current.
37	RC	Resistor connection pin for setting the MR head bias current.
38	RDX	Differential amplifier output pins for the read data. As the output is an open-collector type, connect 100 Ω resistors between each of these pins and V _{cc} .
39	RDY	
40	WUS	Write fault detect pin. Outputs an "H" level when a write fault occurs. As the output is an open-collector type, connect a pull-up resistor.
41	WDX	Write data differential input pins. The input level is pseudo-ECL. Input the differential signals to these pins.
42	WDY	
43	GND	Ground pin. Connect to ground.
44	V _{cc}	Power supply pin. Connect to a +5.0V supply.
45	C2	Capacitor connection pin. Connect a 0.1 mF capacitor between this pin and V _{CC} . The capacitor stabilizes the current source circuit and reduces noise.
46 to 48	HS0, HS1, HS2	Channel 0 to 5 head select pins. See the "n Functions" section for the decoding logic. The input level is TTL.

MB4138

■ BLOCK DIAGRAM

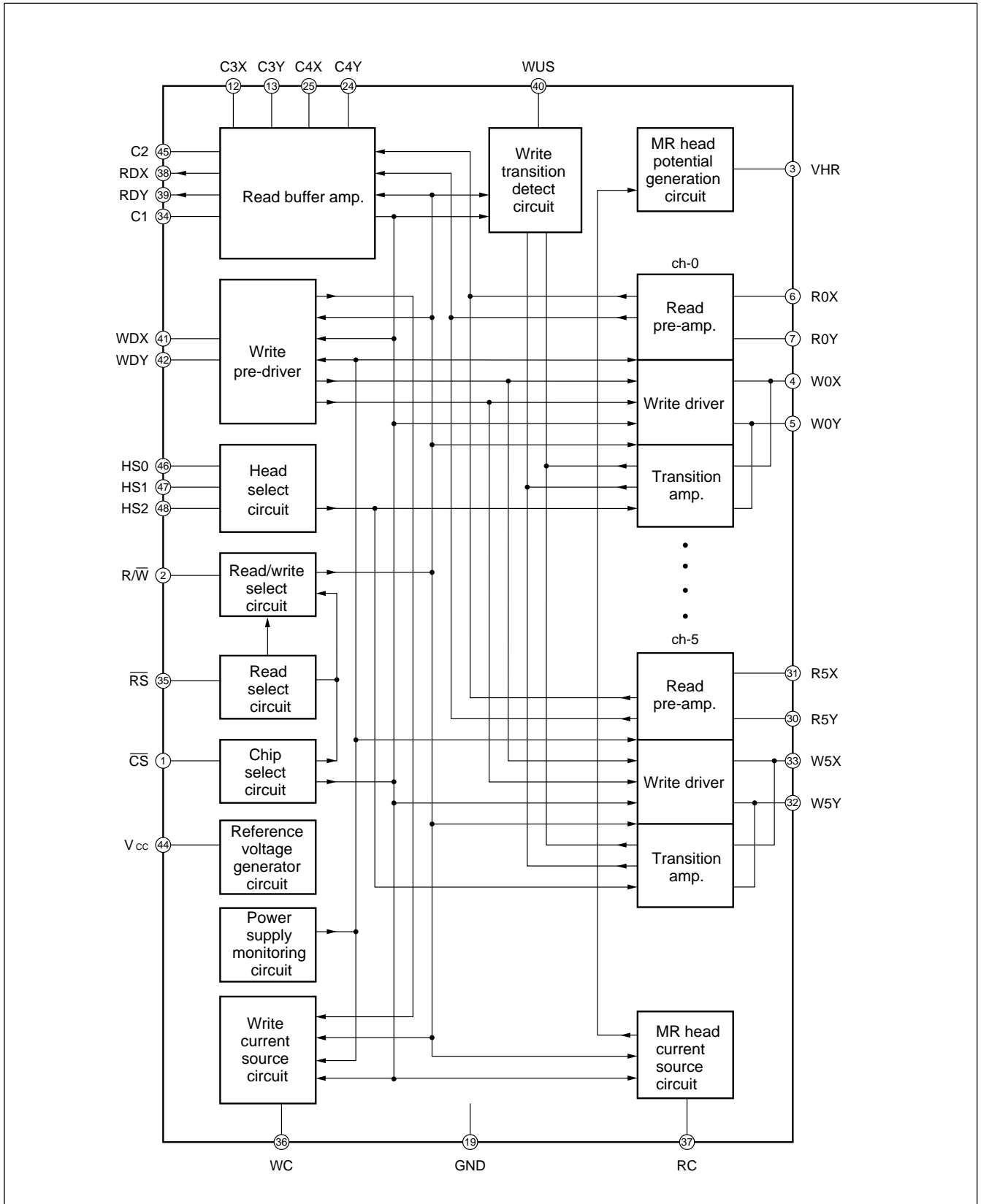

■ ABSOLUTE MAXIMUM RATINGS

Parameter	Symbol	Rating		Unit	Remarks
		Min.	Max.		
Power supply voltage	V _{CC}	-0.3	+7.0	V	
Digital input voltage	V _{IN}	-0.3	V _{CC} +0.3	V	WDX/Y, HS0 to 2, \overline{CS} , R/W, \overline{RS}
Head input voltage	V _{HEAD}	-0.3	V _{CC} +0.3	V	
RDX, RDY output voltage	V _{RDX} , V _{RDY}	-0.3	V _{CC} +0.3	V	
WUS output voltage	V _{WUS}	-0.3	V _{CC} +0.3	V	
WUS output current	I _{WUS}	—	10	mA	
Write current	I _W	—	45	mA	
MR head bias current	I _R	—	15	mA	
Storage temperature	T _{stg}	-55	+125	°C	

■ RECOMMENDED OPERATING CONDITIONS

Parameter	Symbol	Values		Unit	Remarks
		Min.	Max.		
Power supply voltage	V _{CC}	4.50	5.50	V	5.0V±10%
Write current	I _W	10	40	mA	
Write current setting resistor	R _{WC}	24	91	Ω	
MR head bias current	I _R	5	12	mA	
MR head resistor	R _{MR}	20	53	Ω	
MR head current setting resistor	R _{RC}	3k	7.5k	Ω	
Voltage between MR headpins	V _{MR}	0	0.5	V	V _{MR} =I _R × R _{MR}
Operating temperature range	T _{op}	0	+75	°C	

MB4138

■ ELECTRICAL CHARACTERISTICS

1. DC Characteristics

(Unless otherwise specified, $V_{CC}=5.0V \pm 10\%$, $T_a=+25^\circ C$, MR head resistance $R_{MR}=36\Omega$, thin film head $L_h=240\text{ nH}$, $R_h=15\Omega$, $C_1=0.1\ \mu F$, $C_2=0.1\ \mu F$, $C_3=0.033\ \mu F$, $C_4=0.033\ \mu F$)

Parameter	Symbol	Condition	Mode	Values			Unit	Remarks
				Min.	Typ.	Max.		
Power supply current	I_{CC1}	RRC=4.3 k	I	—	5.5	7.5	mA	
	I_{CCR}	RRC=4.3 k	R	—	34	55	mA	
	I_{CCW1}	$\overline{RS}=H$, RWC=32	W1	—	58	80	mA	
	I_{CCW2}	$\overline{RS}=L$, RWC=32 RRC=4.3 k	W2	—	67	90	mA	
Power consumption	P_{DI}	RRC=4.3 k	I	—	27.5	37.5	mW	
	P_{DR}	RRC=4.3 k	R	—	220	325	mW	
	P_{DW1}	RWC=32	W1	—	260	420	mW	
	P_{DW2}	RWC=32, RRC=4.3k	W2	—	355	470	mW	
Operating voltages for supply voltage monitoring	V_{THL}	V_{CC} falling	R/W	3.45	3.90	4.30	V	
	V_{THH}	V_{CC} rising	R/W	3.45	4.10	4.46	V	
Hysteresis width	ΔV_{TH}	$V_{THH} - V_{THL}$	R/W	—	200	—	mV	
WDX, WDY input voltage range	$V_{WDX, YH}$	High level	—	$V_{CC}-1.02$	—	$V_{CC}-0.5$	V	
	$V_{WDX, YL}$	Low level	—	$V_{CC}-1.9$	—	$V_{WDX, YH}-0.25$	V	
WDX, WDY input voltage difference	$\Delta V_{WDX, Y}$	$V_{WDX, YH} - V_{WDX, YL}$	—	250	—	—	mV	
HS0 to 2, \overline{CS} , R/ \overline{W} , \overline{RS} input voltage range	V_{IH}	High level	—	2.0	—	V_{CC}	V	
	V_{IL}	Low level	—	-0.3	—	0.8	V	
WDX, WDY input current	I_{WDX}	$V_{WDX, Y}=V_{CC}/-0.3V$	I/R	-50	0	50	μA	
	I_{WDY}	$V_{WDX, Y}=V_{CC}$	W	—	2	50	μA	
HS input current	I_{HS}	VHS0 to 2= V_{CC}	—	-50	0	50	μA	
		VHS0 to 2= $-0.3V$	—	-250	-120	—	μA	
\overline{CS} , R/ \overline{W} , \overline{RS} input current	ICS IR/ \overline{W} IRS	VCS, R/W, $\overline{RS}=V_{CC}$	—	-50	0	50	μA	
		VCS, R/W, $\overline{RS}=-0.3V$	—	-130	-60	—	μA	
Read head input current	IHR	—	I/W	-50	0	50	μA	
Read head current for non-selected heads	IHRF	—	R	-50	0	50	μA	
MR head current constant	KR	RRC=4.3 k	R	34.3	36.5	38.7	V	KR = IR \times RRC
RC pin voltage	VRC	—	I/R/W	0.88	1.00	1.12	V	

(Continued)

(Continued)

Parameter	Symbol	Condition	Mode	Values			Unit	Remarks
				Min.	Typ.	Max.		
RDX, RDY output current	IRD _{X, Y}	—	R/W	2.0	4.2	6.0	mA	
RDX, RDY output offset	Δ VOFF	Δ VOFF = V _{RDX} - V _{RDY}	R/W	-300	0	300	mV	
Selected read head voltage	VRSH	RRC=4.3 k	R/W2	—	V _{CC} -1.5	—	V	High potential side
Non-selected read head voltage	VRUS	RRC=4.3 k	I/R/W	—	V _{CC} -3.0	—	V	
VHR pin voltage	VVHR	RRC=4.3 k	I/R/W	—	V _{CC} -1.5	—	V	
Read head - VHR voltage difference	Δ VHR	Δ VHR = V _{VHR} - V _{RSH}	R/W2	—	0	180	mV	
C3X, C3Y read current	IC3 _{X, Y}	VC3 _{X, Y} =3V	W	—	0	3	μ A	
Write head input current	IHW	—	I/R	-50	0	50	μ A	
Write head current for non-selected heads	IHWF	—	W	-50	0	50	μ A	
Write current constant	KW	RWC=32	W	0.93	0.98	1.05	V	KW = I _h × RWC
WC pin voltage	VWC1	—	I/R	—	0	100	mV	
	VWC2	—	W	0.93	1.05	1.17	V	
Head clip voltage	VCL1, 2	RWC=32	W	—	2.0	—	V	
Head clip voltage difference	Δ VCL	Δ VHR = VCL1 - VCL2	W	—	0	250	mV	
WUS output current	IWUS	RWUS=1 k	I/R	—	0	50	μ A	

MB4138

2. AC Characteristics

(Unless otherwise specified, $V_{CC}=5.0V\pm 10\%$, $T_a=+25^\circ\text{C}$, MR head resistance $RMR=36\Omega$, thin film head $L_h=240\text{ nH}$, $R_h=15\Omega$, $C_1=0.1\ \mu\text{F}$, $C_2=0.1\ \mu\text{F}$, $C_3=0.033\ \mu\text{F}$, $C_4=0.033\ \mu\text{F}$)

Parameter	Symbol	Condition	Mode	Values			Unit	Remarks
				Min.	Typ.	Max.		
Differential voltage gain	G_D	$V_{in}=1\text{mVpp}$, $f_{in}=5\text{ MHz}$	R	100	150	220	V/V	$R_L=100\Omega$
Frequency bandwidth	B_W	$V_{in}=1\text{mVpp}$, $G_D=-3\text{ dB}$	R	55	75	—	MHz	$R_L=100\Omega$
Input capacitance	C_I	—	R	—	18	—	pF	
Input conversion noise voltage	V_n	$BW=1\text{ to }30\text{MHz}$, pin short	R	—	0.51	0.69	$\text{nV}/\sqrt{\text{Hz}}$	
Input dynamic range	DR	$f_{in}=5\text{ MHz}$, $3f_{in}=-30\text{ dB}$	R	5	—	—	mVpp	
Common mode rejection ratio	CMRR	$V_{in}=100\text{ mVpp}$, $f_{in}=5\text{ MHz}$	R	40	—	—	dB	
Power supply rejection ratio	PSRR	$V_{in}=100\text{ mVpp}$, $f_{in}=5\text{ MHz}$	R	40	—	—	dB	
Channel separation	CSP	$V_{in}=100\text{ mVpp}$, $f_{in}=5\text{ MHz}$	R	40	—	—	dB	
$\overline{\text{CS}}$ delay	t_{dIR}	$RRC=4.3\text{ k}$	IR	—	—	20	μs	
	t_{dRI}	$RRC=4.3\text{ k}$	RI	—	—	1	μs	
	t_{dIW}	$RWC=24$	IW	—	250	500	μs	
	t_{dWI}	$RWC=24$	WI	—	100	500	μs	
R/ $\overline{\text{W}}$ delay	t_{dWRR}	$RRC=4.3\text{ k}$, $RMR=36$, $RS=H$	W1R	—	—	3.0	μs	$t_{WG}=1\text{ms}$ For a 1ms write time
		$RRC=4.3\text{ k}$, $RMR=36$, $RS=L$	W2R	—	—	3.0	μs	
		$RRC=3.0\text{ k}$, $RMR=53$, $RS=L$	W2R	—	—	3.5	μs	
	t_{dRWR}	$RRC=4.3\text{ k}$	RW	—	—	1	μs	
	t_{dRWW}	$RWC=24$	RW	—	250	500	ns	
	t_{dWRW}	$RWC=24$	RW	—	100	500	ns	
RS delay	t_{dW12}	$RRC=4.3\text{ k}$	W1W2	—	—	1	μs	
	t_{dW21}	$RRC=4.3\text{ k}$	W2W1	—	—	3	μs	
HS delay	t_{dHSR}	$RMR=30 \leftrightarrow 41$ (at head switching)	R	—	—	40	μs	
	t_{dHSW}	$RWC=24$	W	—	—	500	ns	
WUS delay	t_{dSF}	f_{WDX} , $Y=0 \rightarrow 2\text{ MHz}$	W	—	—	1	μs	
	t_{dUS}	f_{WDX} , $Y=20 \rightarrow 0\text{ MHz}$	W	0.6	1.2	3.6	μs	
Write current transition time	t_{r1}/t_{f1}	$RWC=24$, $L_h=240\text{ nH}$, $R_h=15$	W	—	9	—	ns	
Transition time difference	Δt_{pd}	$ t_{r1} - t_{f1} $	W	—	—	1	ns	

(Continued)

(Continued)

Parameter	Symbol	Condition	Mode	Values			Unit	Remarks
				Min.	Typ.	Max.		
Write current delay	tpd1, 2	RWC=24, Lh=240 nH, Rh=15	W	—	4.5	—	ns	
Delay time difference	Δt_{rf}	tpd1 – tpd2	W	—	—	1	ns	
Write data input frequency	fWDX, Y	RWC=24, Lh=240nH, Rh=15	W	1.6	—	31.5	MHz	
WUS output voltage	VUSL	fWDX, Y=2MHz, IWUS=5mA	W	—	0.1	0.5	V	
WUS output current	IUSH	fWDX, Y=0MHz, Rh=15	W	—	0	50	μ s	
		fWDX, Y=9MHz, Write head open	W	—	0	50	μ s	IW=40mA

MB4138

■ FUNCTIONS

1. Mode Selection

Operation Mode	MR Bias Current	CS Pin Voltage	R/W Pin Voltage	R \bar{S} Pin Voltage
Idle (I)	OFF	H	—	—
Read (R)	ON	L	H	—
Write 1 (W1)	OFF	L	L	H
Write 2 (W2)	ON	L	L	L

2. Head Selection

Head	HS0	HS1	HS2
0	L	L	L
1	H	L	L
2	L	H	L
3	H	H	L
4	L	L	H
5	H	L	H

3. WUS (Write Unsafe) Output Truth Table

Operation mode	Conditions	WUS
Idle (I)	—	H
Read (R)	—	H
Write (W)	Normal	L
	When one or more of the following faults is present: <ul style="list-style-type: none"> • Write data frequency too low. • Write head pin is open (fWD < 9MHz). • No write current, or current is too low. 	H

■ OPERATION

1. Read Mode

In read mode, the MB4138 operates as a low noise differential amplifier. A bias current (sense current) flows through the MR head from the RiX pin to the RiY pin.

The MR head bias current (I_R) is determined by the MR head current constant (KR) and the resistance (RRC) connected between the RC pin and GND pin. The current is calculated as follows.

$$I_R = KR/RRC$$

The RiX and RiY pins are connected directly to the bias current circuit and to the bases of the two opposite transistors of the differential amplifier circuit (read amp). Therefore, differential amplification of the read signal from the MR head is performed directly. The emitters of the two opposite transistors of the differential amplifier circuit require capacitive coupling to cut the DC component generated by the MR head resistance and bias current. (Connect 0.033 μ F capacitors across C3X - C3Y and C4X - C4Y).

RDX and RDY are open-collector output pins for the read buffer circuit. RiX and RDX, and RiY and RDY have the same phase.

The output voltages (DC) of RDX and RDY are almost the same for write and read modes. This reduces the transient time when switching from write to read mode.

Connect 0.1 μ F capacitors across C1 - GND and C2 - Vcc to stabilize the current source circuit for the MR head bias current.

In all modes, the VHR pin outputs the same voltage as the RiX pin of the channel selected for read mode. The potential difference between the MR head and disk can be eliminated by biasing the disk with this voltage.

2. Write Mode

In write mode, the MB4138 switches the current through the thin film head (I_h) at high speed. The write current (I_w) is determined by the write current constant (KW) and the resistance connected between the WC pin and ground (RWC). The currents are calculated as follows.

$$I_w = VWC/RWC$$

$$I_h = \frac{I_w \times 0.99}{1 + Rh/Rd} = KW/RWC$$

Rh: Thin film head resistance

Rd: IC internal damping resistance

The write fault detection circuit detects abnormalities in the thin film head and its connection pins (WiX and WiY). The circuit generates an alarm on detecting a fault.

Normally, no bias current flows in the MR head during write mode. However, to reduce the transient time when switching from write to read mode, a bias current can be flowed by setting the RS pin at the "L" level.

3. Idle Mode

Neither the read nor write circuits operate in idle mode.

However, the VHR pin continues to operate and output a voltage in idle mode.

MB4138

■ TIMING CHART

1. $\overline{\text{CS}}$ Delay

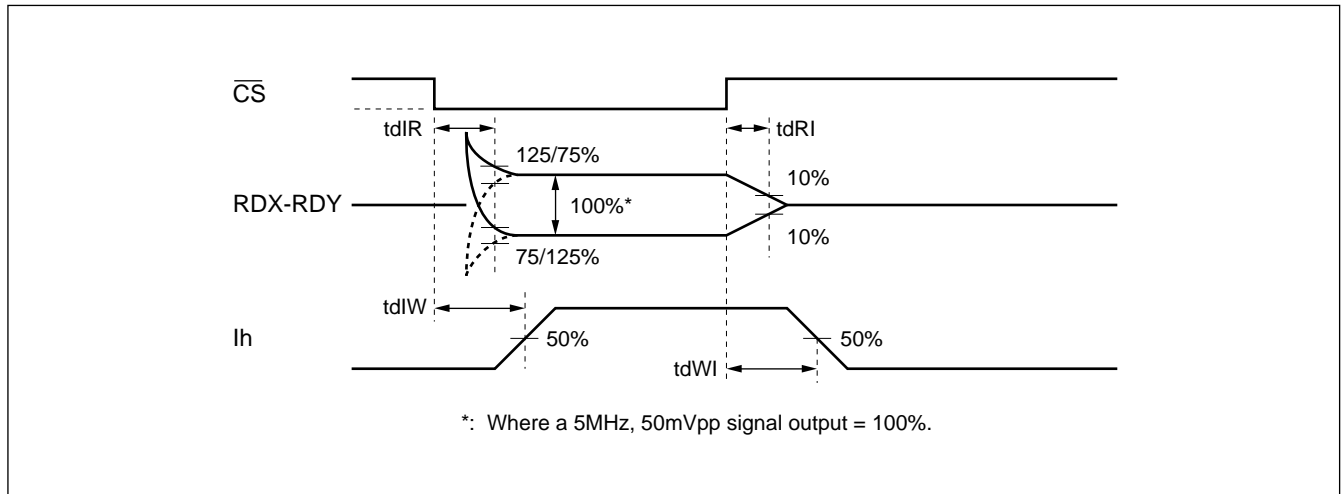

2. $\text{R}/\overline{\text{W}}$ Delay

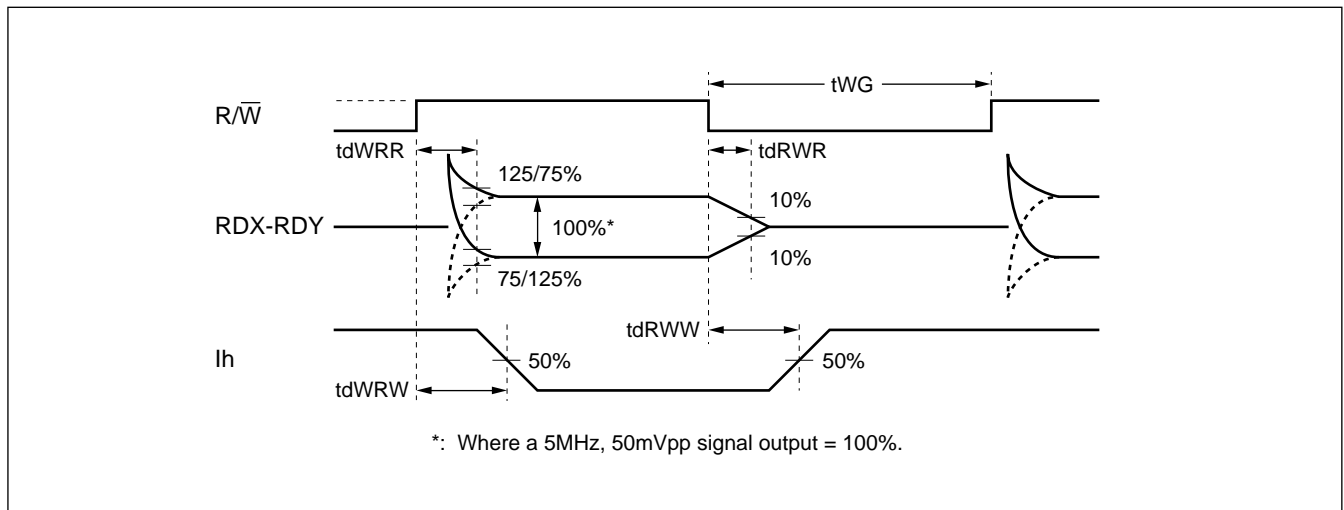

3. $\overline{\text{RS}}$ Delay

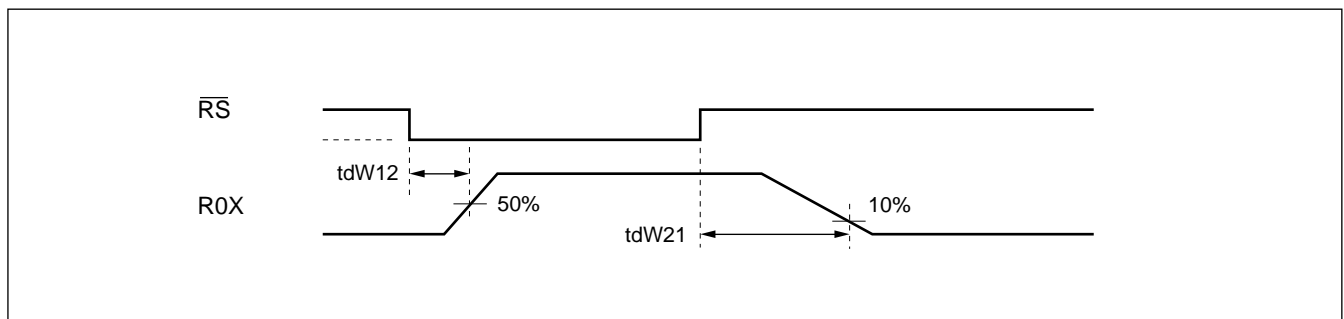

4. HS Delay

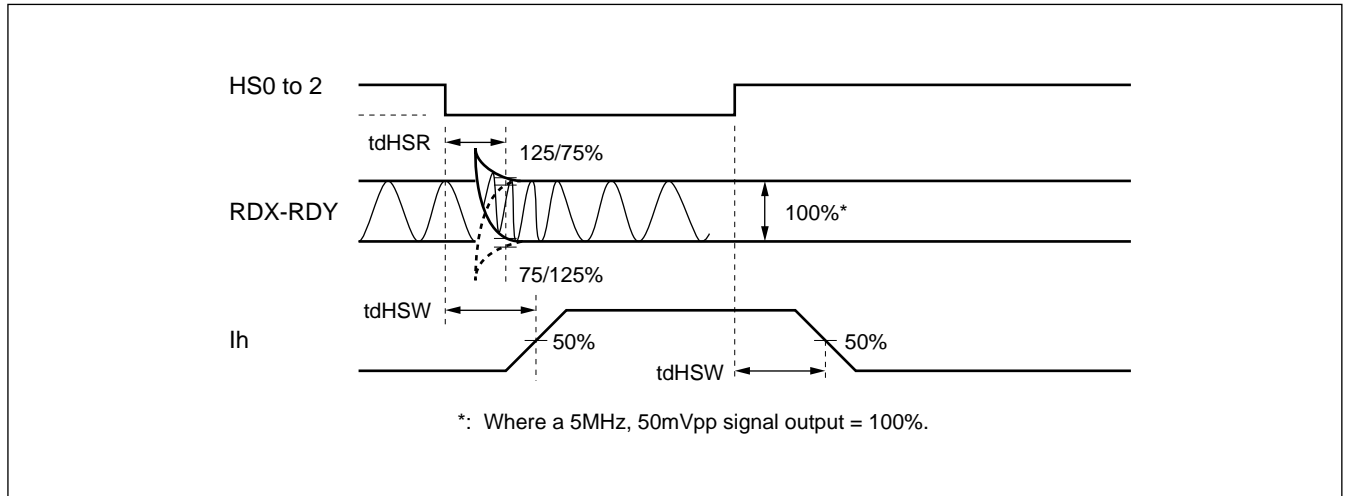

5. WUS Delay

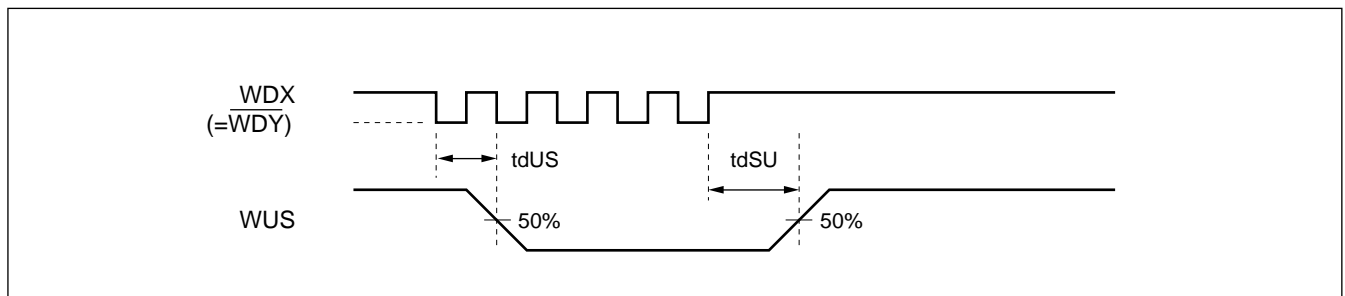

6. Write Current Transition Time, Write Current Delay

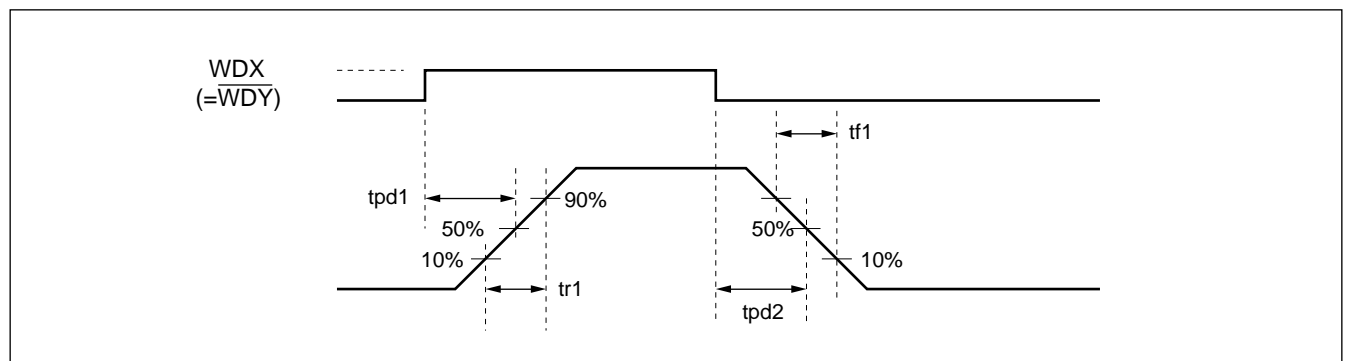

MB4138

APPLICATION CIRCUIT EXAMPLE

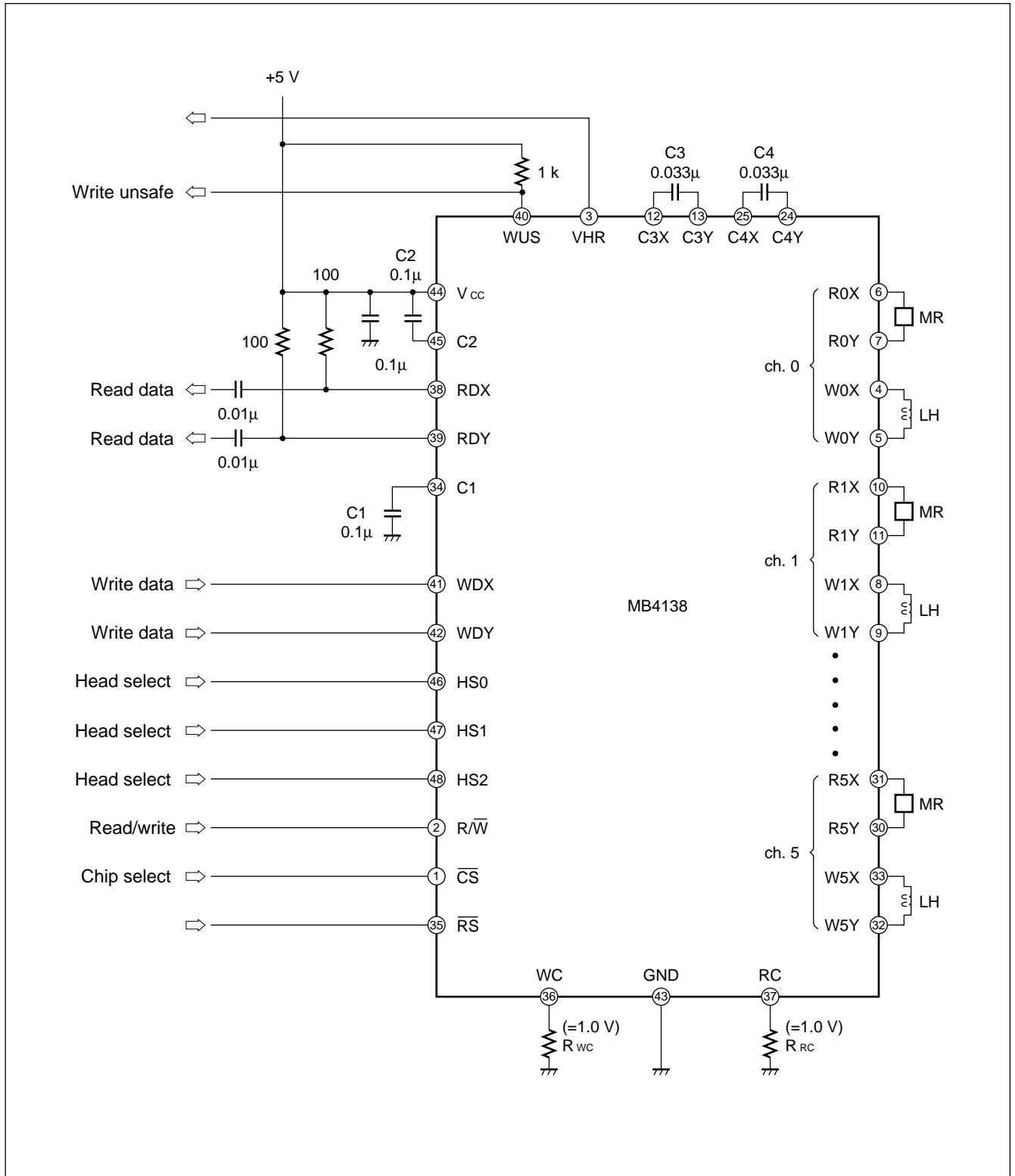

■ ORDERING INFORMATION

Part Number	Package	Remarks
MB4138PFQ	48-pin, Plastic QFP (FPT-48P-M13)	

MB4138

■ PACKAGE DIMENSION

48-pin, Plastic QFP
(FPT-48P-M13)

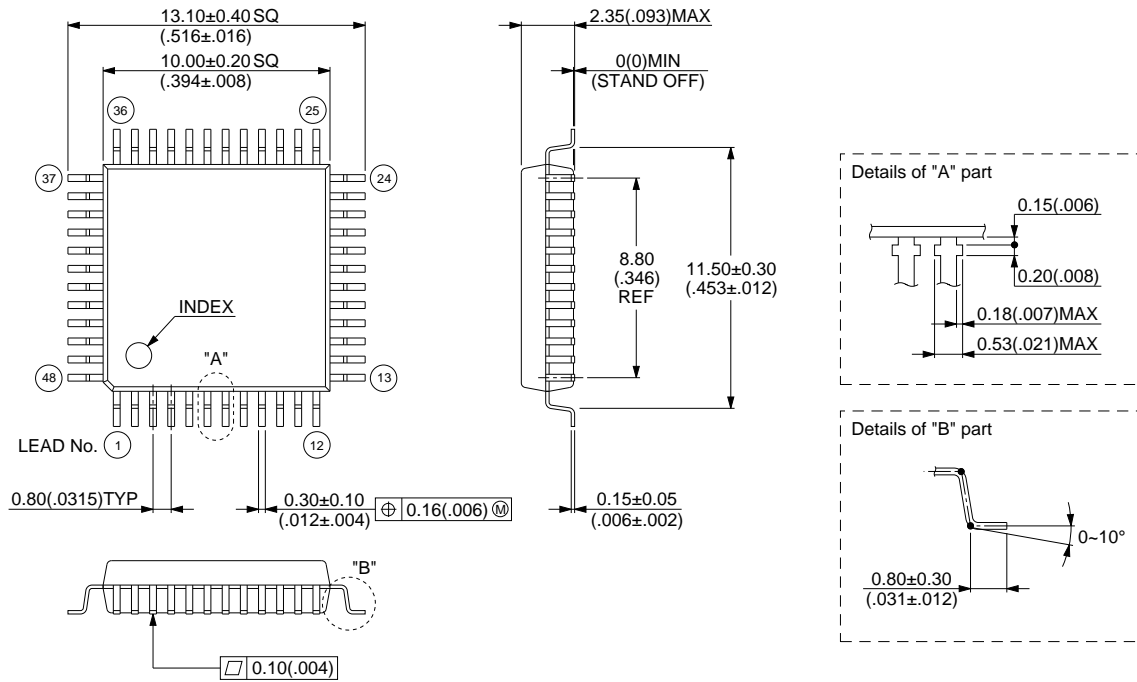

© 1994 FUJITSU LIMITED F48023S-1C-1

Dimensions in mm (inch).

MB4138

FUJITSU LIMITED

For further information please contact:

Japan

FUJITSU LIMITED
Corporate Global Business Support Division
Electronic Devices
KAWASAKI PLANT, 4-1-1, Kamikodanaka
Nakahara-ku, Kawasaki-shi
Kanagawa 211-88, Japan
Tel: (044) 754-3753
Fax: (044) 754-3329

North and South America

FUJITSU MICROELECTRONICS, INC.
Semiconductor Division
3545 North First Street
San Jose, CA 95134-1804, U.S.A.
Tel: (408) 922-9000
Fax: (408) 432-9044/9045

Europe

FUJITSU MIKROELEKTRONIK GmbH
Am Siebenstein 6-10
63303 Dreieich-Buchsschlag
Germany
Tel: (06103) 690-0
Fax: (06103) 690-122

Asia Pacific

FUJITSU MICROELECTRONICS ASIA PTE. LIMITED
#05-08, 151 Lorong Chuan
New Tech Park
Singapore 556741
Tel: (65) 281 0770
Fax: (65) 281 0220

All Rights Reserved.

The contents of this document are subject to change without notice. Customers are advised to consult with FUJITSU sales representatives before ordering.

The information and circuit diagrams in this document presented as examples of semiconductor device applications, and are not intended to be incorporated in devices for actual use. Also, FUJITSU is unable to assume responsibility for infringement of any patent rights or other rights of third parties arising from the use of this information or circuit diagrams.

FUJITSU semiconductor devices are intended for use in standard applications (computers, office automation and other office equipment, industrial, communications, and measurement equipment, personal or household devices, etc.).

CAUTION:

Customers considering the use of our products in special applications where failure or abnormal operation may directly affect human lives or cause physical injury or property damage, or where extremely high levels of reliability are demanded (such as aerospace systems, atomic energy controls, sea floor repeaters, vehicle operating controls, medical devices for life support, etc.) are requested to consult with FUJITSU sales representatives before such use. The company will not be responsible for damages arising from such use without prior approval.

Any semiconductor devices have inherently a certain rate of failure. You must protect against injury, damage or loss from such failures by incorporating safety design measures into your facility and equipment such as redundancy, fire protection, and prevention of over-current levels and other abnormal operating conditions.

If any products described in this document represent goods or technologies subject to certain restrictions on export under the Foreign Exchange and Foreign Trade Control Law of Japan, the prior authorization by Japanese government should be required for export of those products from Japan.

F9703

© FUJITSU LIMITED Printed in Japan